

SERVICE MANUAL

NAD MODEL 3080

STEREO AMPLIFIER

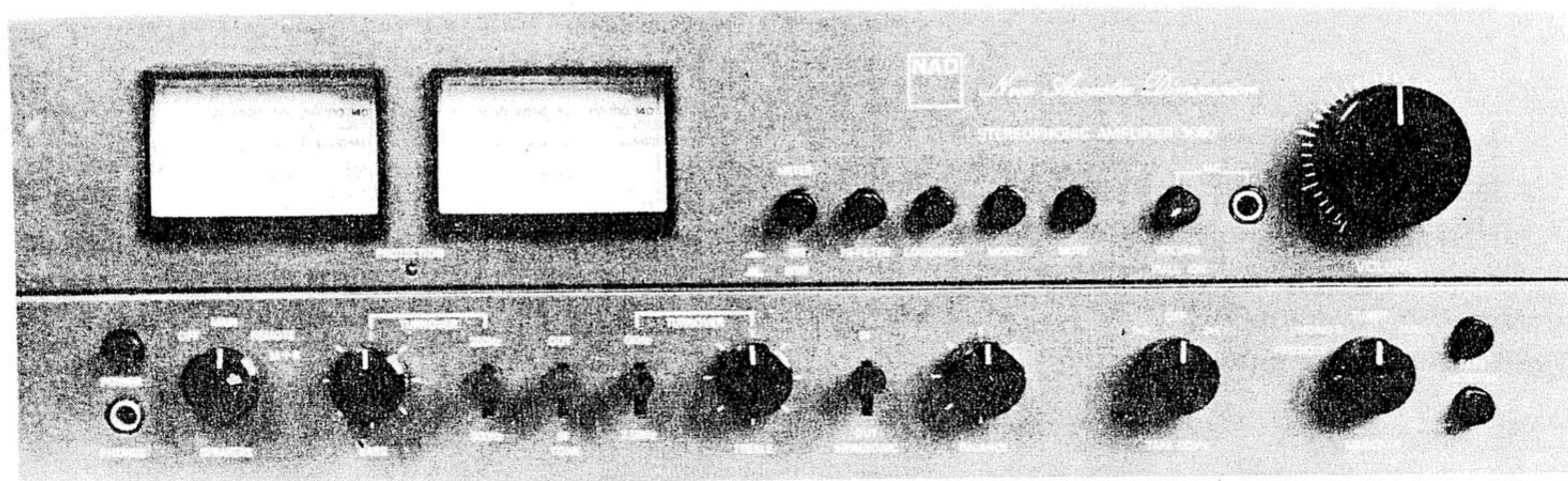

CONTENTS

SPECIFICATION	PAGE	2
INSIDE VIEW OF UNIT	PAGE	3
ALIGNMENT	PAGE	4, 5
PCB PARTS LOCATION	PAGE	6, 7
WIRING DIAGRAM	PAGE	8
CIRCUIT DIAGRAM	PAGE	9
PARTS LIST	PAGE	10, 11, 12, 13

SPECIFICATION

* Measurements identified by an asterisk are taken in accordance with the new IHF A-202 amplifier measurement standard.

Power Amplifier Section

* Continuous average power output at 8 ohms 20–20K Hz both channel driven	90W
Rated distortion, 20–20K Hz	< 0.03%
* Clipping headroom at 8 ohms	+1.6db
Clipping power at 8 ohms	130W
at 4 ohms	160W
at 2 ohms	180W
Dynamic headroom at 8 ohms	+2.5db
Dynamic power at 8 ohms	160W
at 4 ohms	200W
at 2 ohms	220W
* Reactive load rating	+2.5db
* Transient Overload Recovery Time	< 1usec
* Slew Factor	> 50
Slew Rate	40V/Nsec
Damping factor at 50 Hz (Ref. 8 ohms)	120
T.H.D. 20–20K Hz From 250 mW to 80W	< 0.03%
S.M.P.T.E. I.M.D. (60 Hz + 7KHz, 4:1) From 250mW to 80W	< 0.04%
I.H.F. I.M.D. (19KHz + 20KHz) at 80W	< 0.03%
T.I.M. (15KHz Sine + 3.18KHz Square Wave) at 80W	< 0.03%
Frequency Response, 20–20K HZ	± 0.5db
Frequency Response Range ± 3dB	5–50kHz

Preamplifier Section

* Input Impedance Resistance/Capacitance	47kΩ/47PF
Input Sensitivity (1KHz) * For 1 watt out	0.25mV
80Watt out	2.5mV
Input Overload at 1KHz	200mV
20 Hz	20mV
20 KHz	2.0V
THD (20–20K Hz) and IMD at + 30dB input level	< 0.01%
RIAA Response Accuracy	± 0.3db
Signal to Noise Ratio A-weighted	
(a) with phono cartridge connected Ref 10mV	> 82db
* Ref 5mV	> 76 db
(b) with short-circuit input Ref 10mV	> 90db

High level input

* Input impedance Resistance/Capacitance	50kΩ/100PF
Input sensitivity * For 1 watt out	16mV
For 80 watt out	150mV
Signal to Noise Ratio, A-Weighted	
(a) with mute off * Ref 1 watt out	> 80db
Ref 80 watt out	> 95db
(b) with mute on Ref 1 watt out	> 85db
* Maximum input signal	Infinite
Frequency Response, 20–20K Hz	± 0.5db

Controls

Bass control, range at 50 Hz	± 11 and ± 13db
Treble control, range at 10 KHz	± 6 and ± 9db
Infrasonic filter Turn over frequency	20Hz
Slope (dB/octave)	12
High filter Turn over frequency	8KHz
Slope (dB/octave)	12
Mute	-20db

Physical Specification

Dimensions	W x H x D	inch	19.3x5.5x15.6
		cm	49x14.x39.5
Net weight			3.5lbs/16kg
Shipping weight			41lbs/18.5kg
Power Consumption at 1 watt out			30VA
80 watt out			400VA

INSIDE VIEW OF UNIT

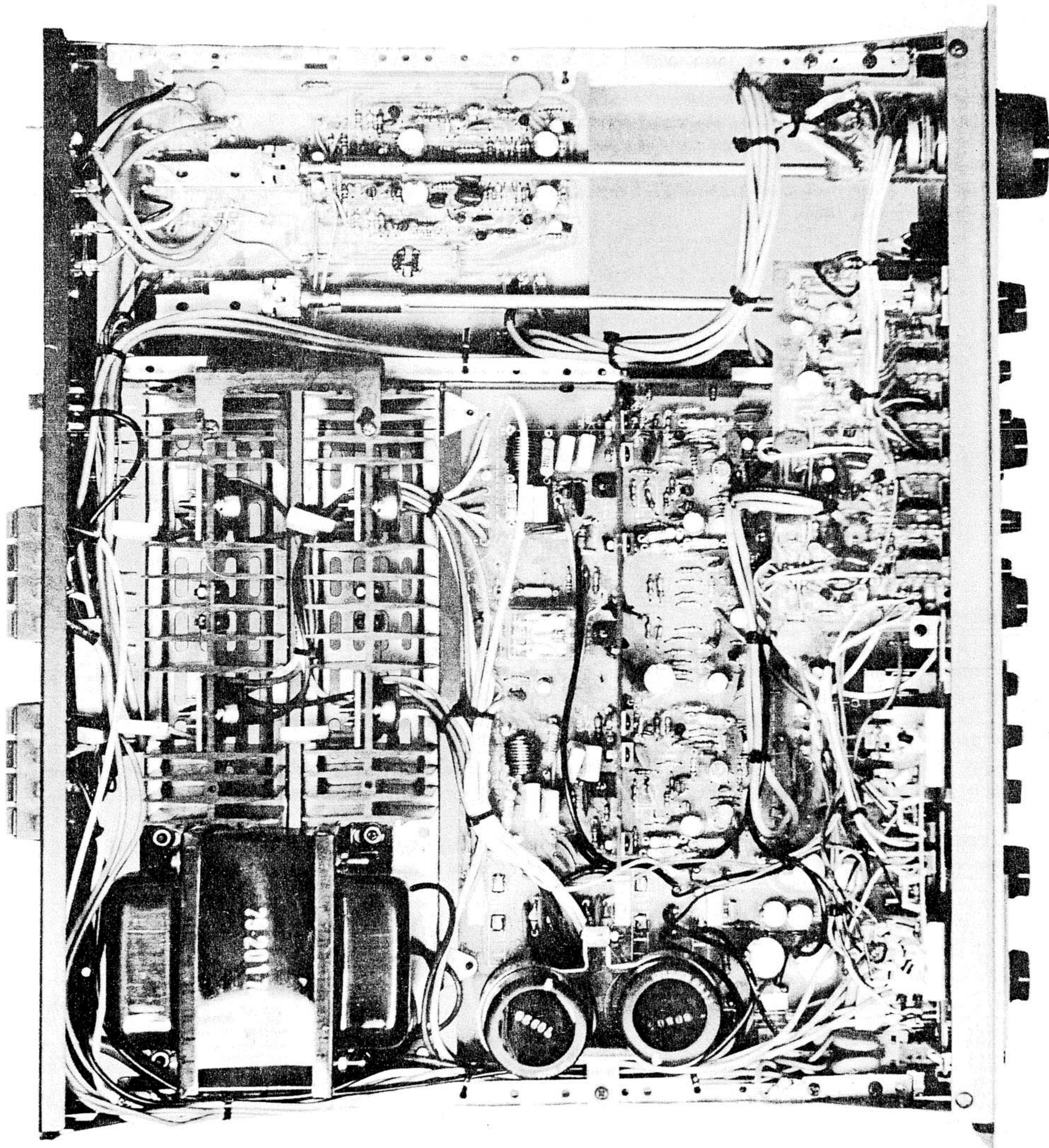

ALIGNMENT

1. IDLE CURRENT ALIGNMENT

1. 5 Minutes minimum pre-heating is necessary for idle current alignment.
 2. Set the volume control at minimum position.
 3. Speaker switch should be set at off position.
 4. Connect DC voltmeter across R638 for right channel and across R637 for left channel. (see fig. 1)
 5. Record the reading of DC voltmeter and refer to the following chart to find the appropriate value resistor to connect in parallel with R622 (right channel), or R621 (left channel) on the bottom side (pattern side) of PCB.
- * Important notice: The power switch must be in the off position when soldering is done.

Reading of DC Voltmeter	Parallel Resistor	Reading of DC Voltmeter	Parallel Resistor
0.5 to 1.0mV	820 ohm	2.5 to 3.5mV	1k8 ohm
1.0 to 1.5mV	1k ohm	3.5 to 4.5mV	2k2 ohm
1.5 to 2.0mV	1k2 ohm	4.5 to 5.5mV	2k7 ohm
2.0 to 2.5mV	1k5 ohm	5.5 to 7.0mV	3k3 ohm

6. Read the DC voltage across to R638 (right channel) and R637 (left channel) again.
7. If the DC voltage were between 6mV and 9mV, then the alignment is completed.
8. If the DC voltage were less than 6mV, the value of parallel resistor should be decreased until the DC voltage is between 6mV and 9mV.
9. If the DC voltage were more than 9mV, the value of parallel resistor should be increased until the DC voltage is between 6mV and 9mV.

2. POWER METER ALIGNMENT

1. Feed a 1KHz sine wave approx 150mV RMS to both channel's Aux inputs.
 2. Connect an 8 ohm (+20%) dummy load and an AC voltmeter and oscilloscope to the "main speaker" terminals on the rear panel.
 3. Set the volume control at maximum position and other controls are set at their normal positions.
 4. Set the speaker switch to "main" position.
- * 5. Adjust the input signal level till the output voltage is 25.3 V making sure that no clipping of the waveform is occurring.
6. Adjust VR201 (for right channel) and VR202 (for left channel) for a meter indication of 80 W. (or 0 dB). (sec. fig. 3)
- * In cases of poor mains regulation it is possible that slight clipping occurs at 25.3 V when both channels are driven simultaneously. If this is the case, do the calibration one channel at a time.

ALIGNMENT

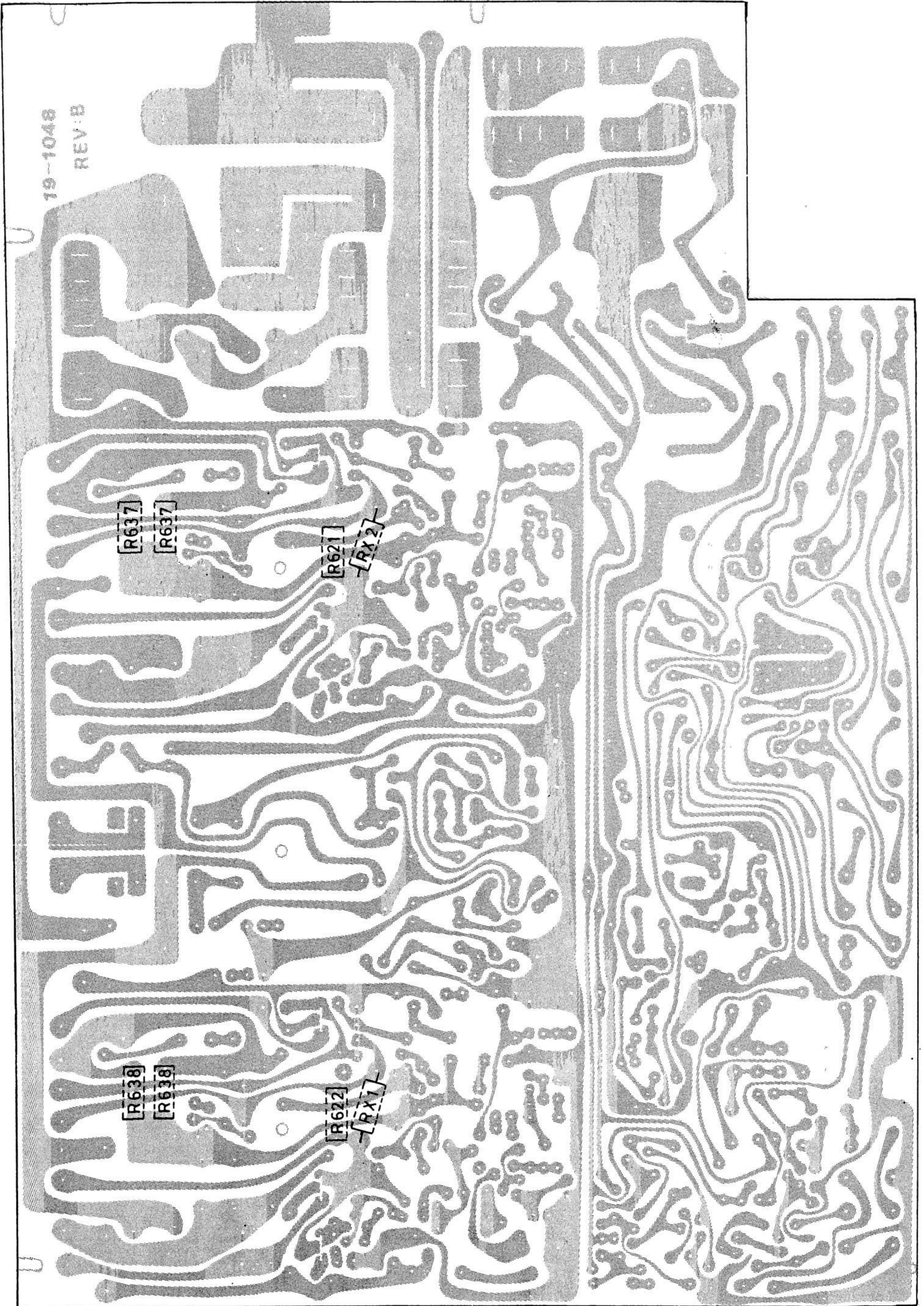

Fig. 1

PCB PARTS LOCATION

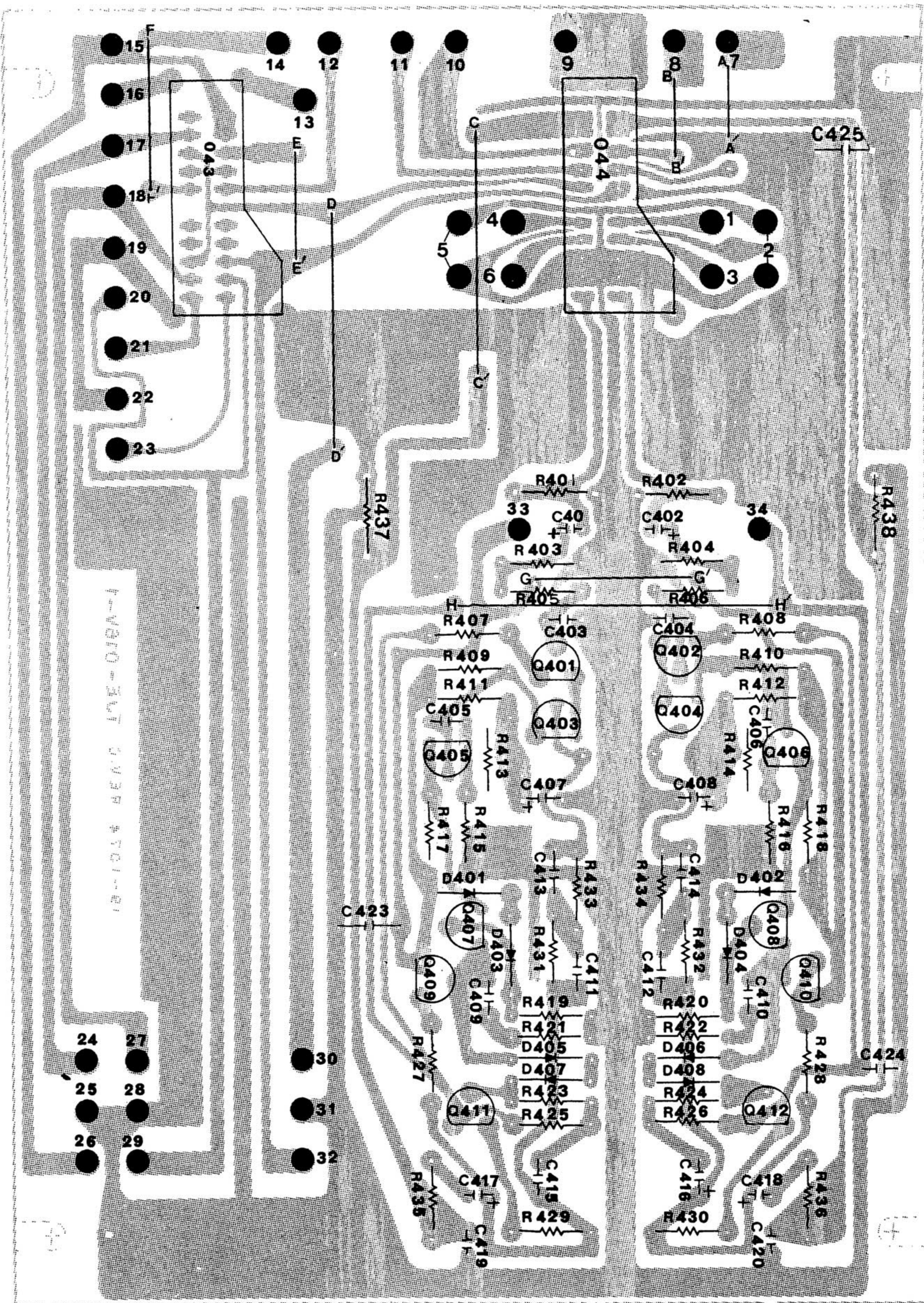

Fig. 2

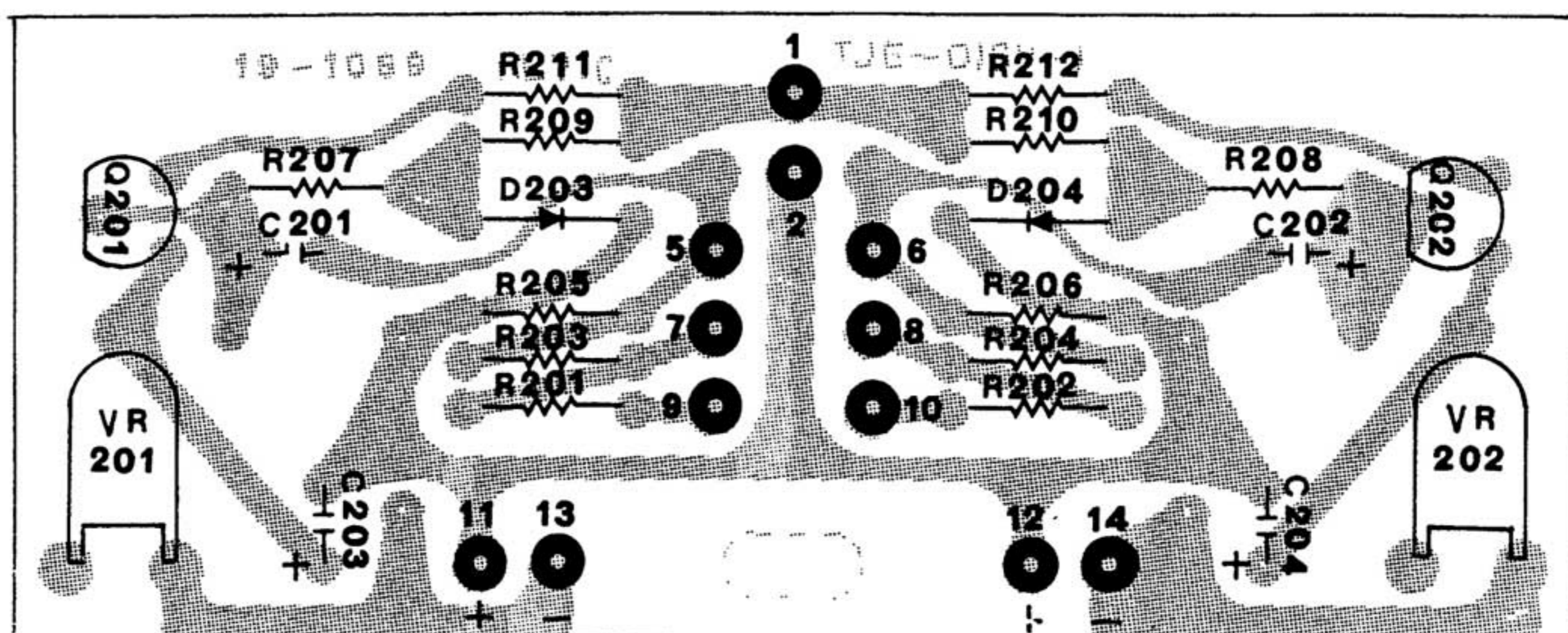

Fig. 3

PCB PARTS LOCATION

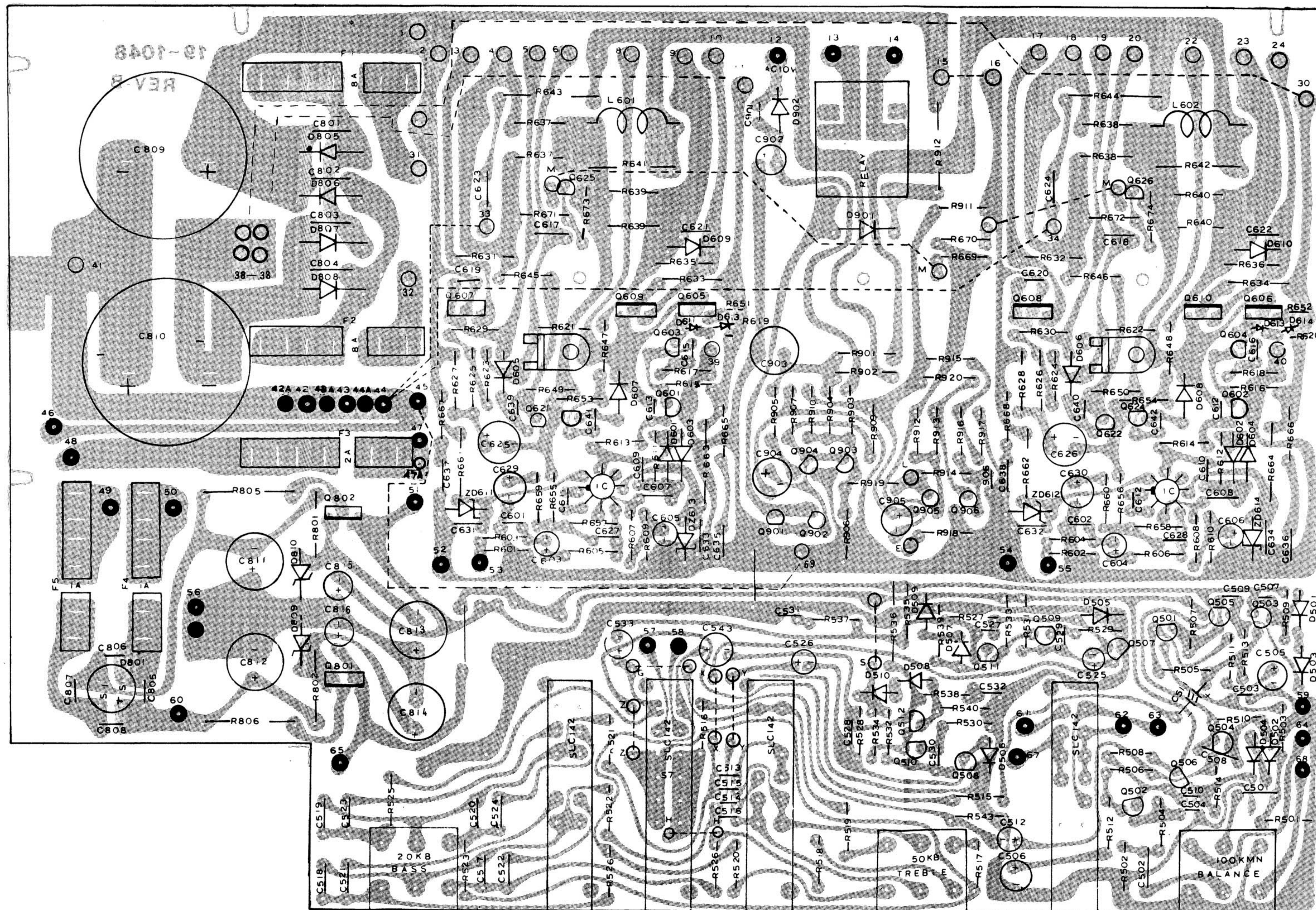
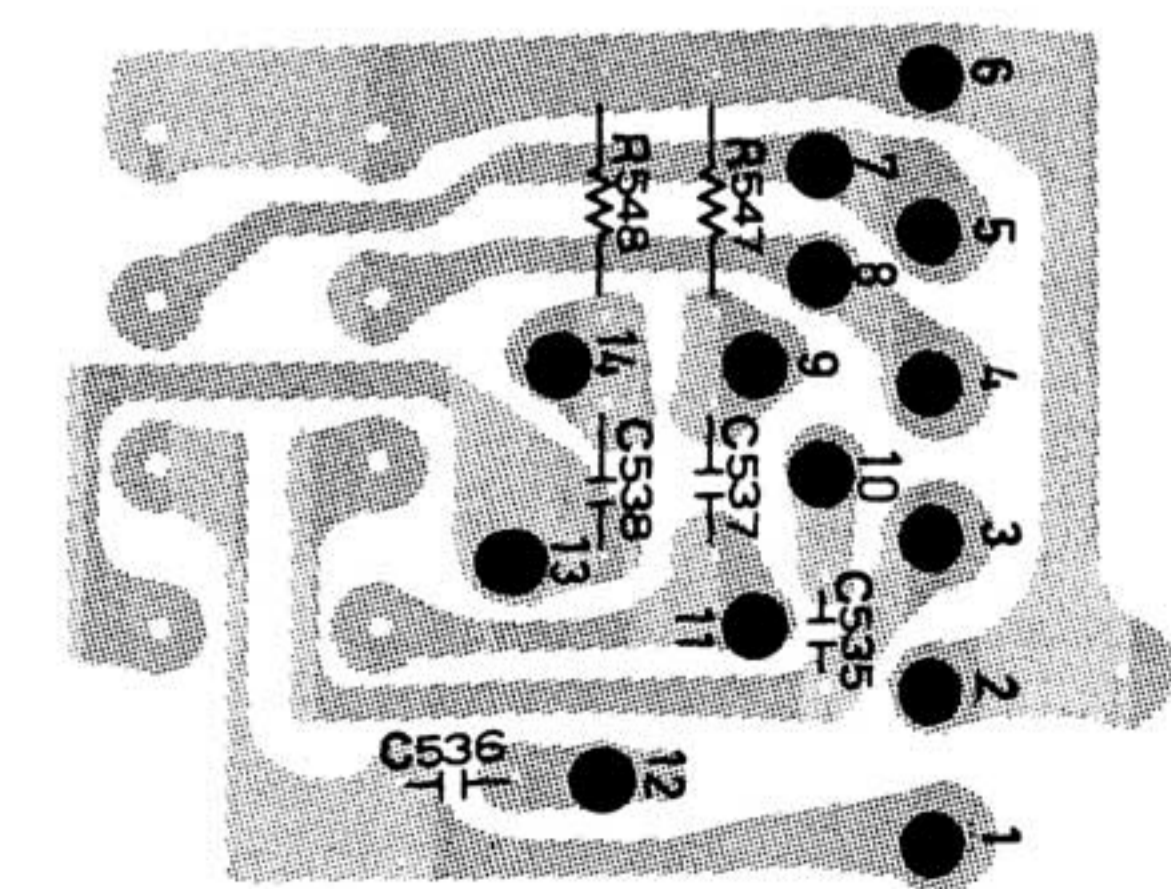
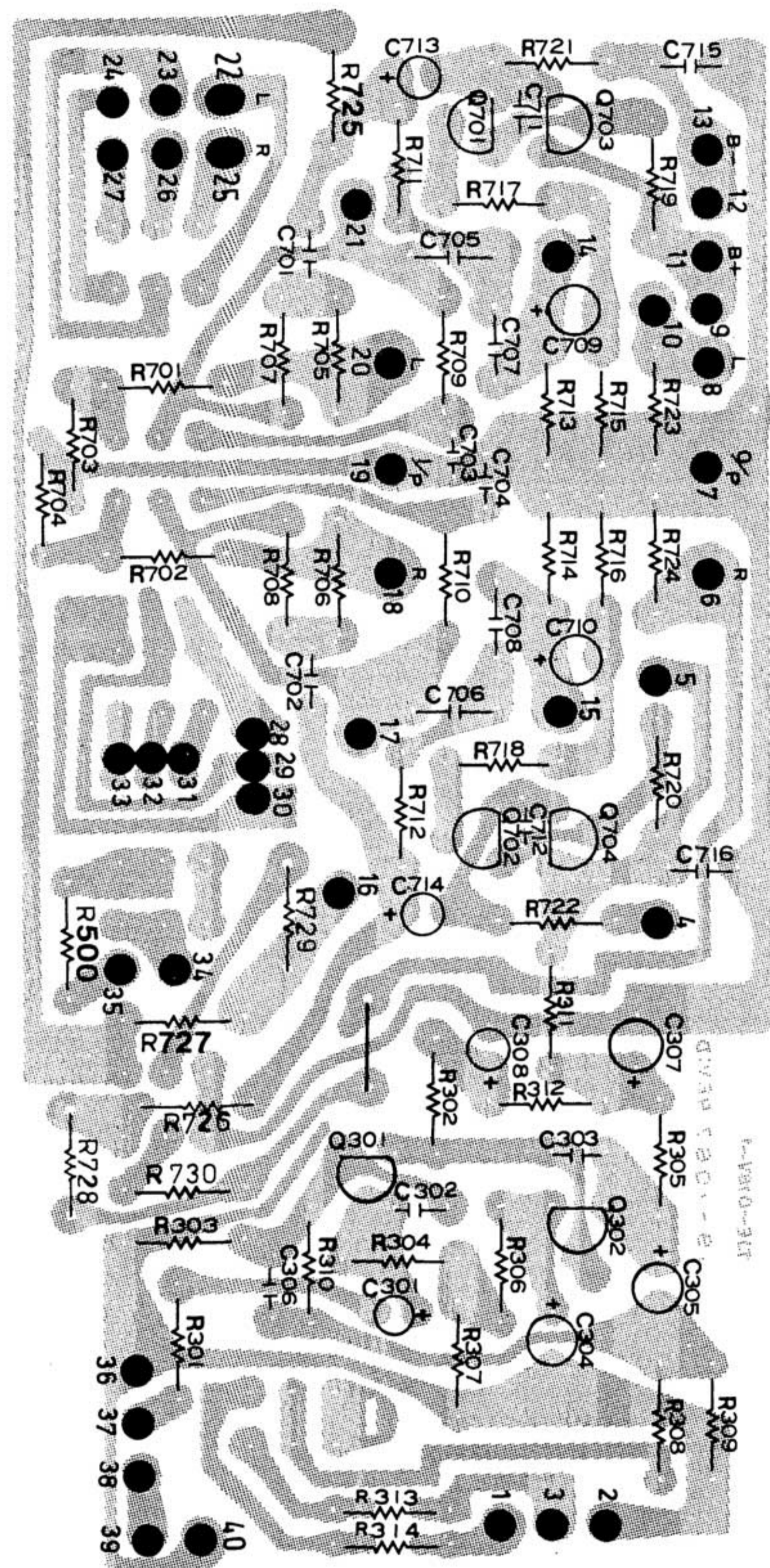
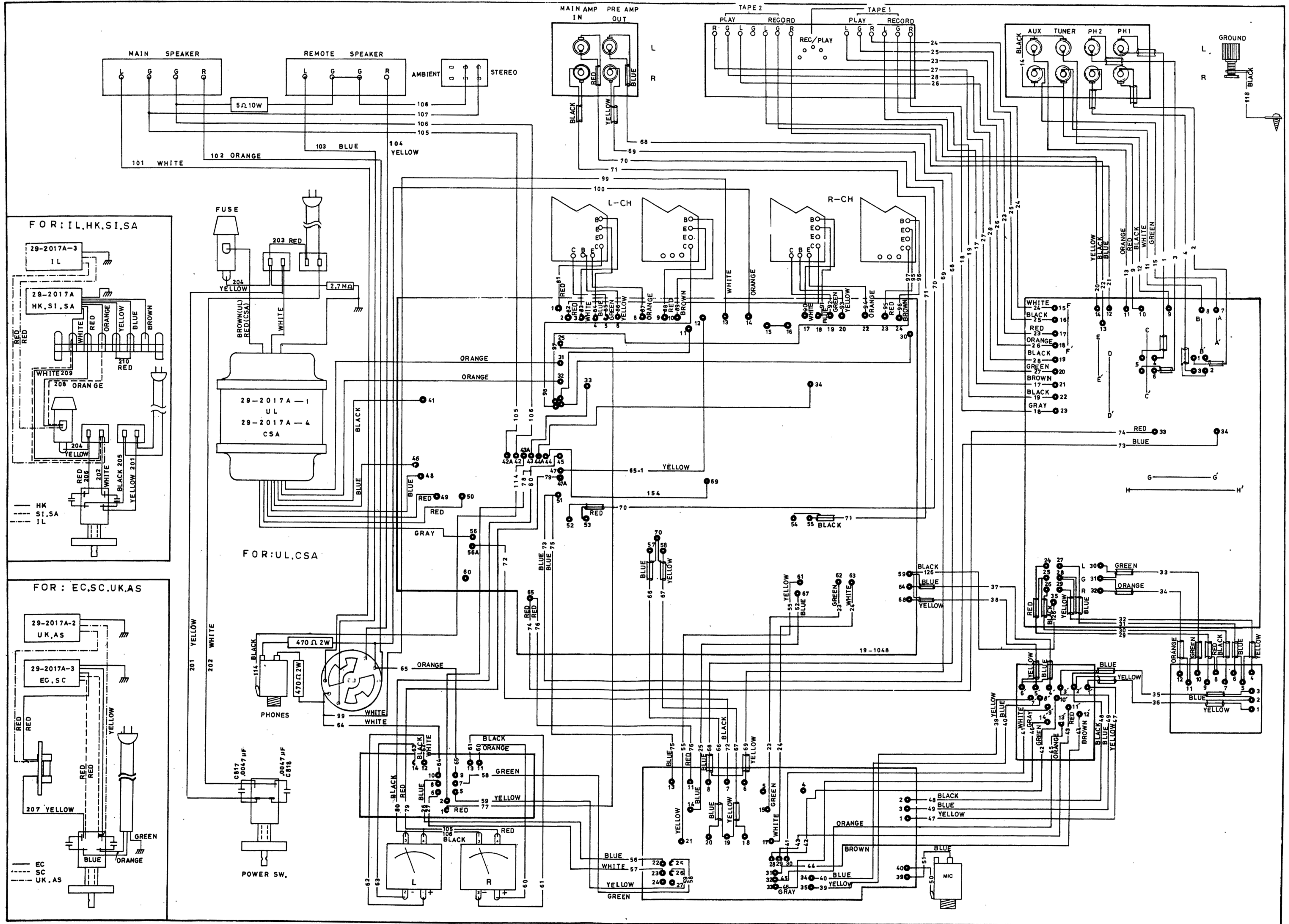

Fig. 4

Fig. 5

WIRING DIAGRAM



CIRCUIT DIAGRAM

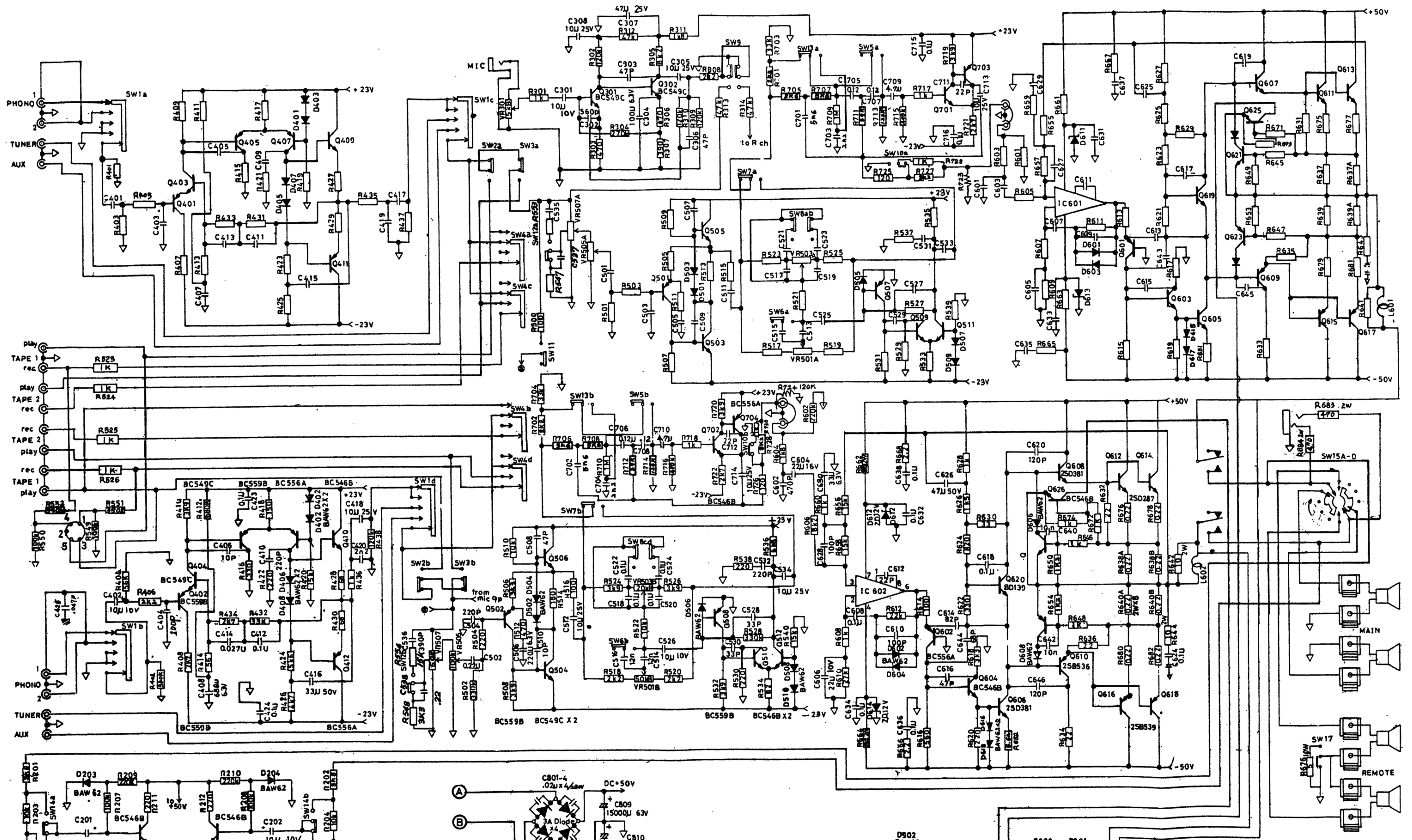

SW1a,b,c,d	Function Sw.	SW10a,b	Audio Mute Sw.
SW2a,b	Tape 1 Sw.	SW11	Mono/Stereo Sw.
SW3a,b	Tape 2 Sw.	SW12a,b	Loudness Sw.
SW4a,b,c,d	Tape Copy Sw.	SW13a,b	Hi-Filter Sw.
SW5a,b	Infraonic In/Out Sw.	SW14a,b	8W/80W Meter Sw.
SW6a,b	25/5 Hz Sw.	SW15A-D	Speaker Sw.
SW7a,b	Tone In/Out Sw.	SW16	Power Sw.
SW8a,b,c,d	500/250 Hz Sw.	SW17	Stereo/Ambient Sw.
SW9	Mic In Sw (Pull)		

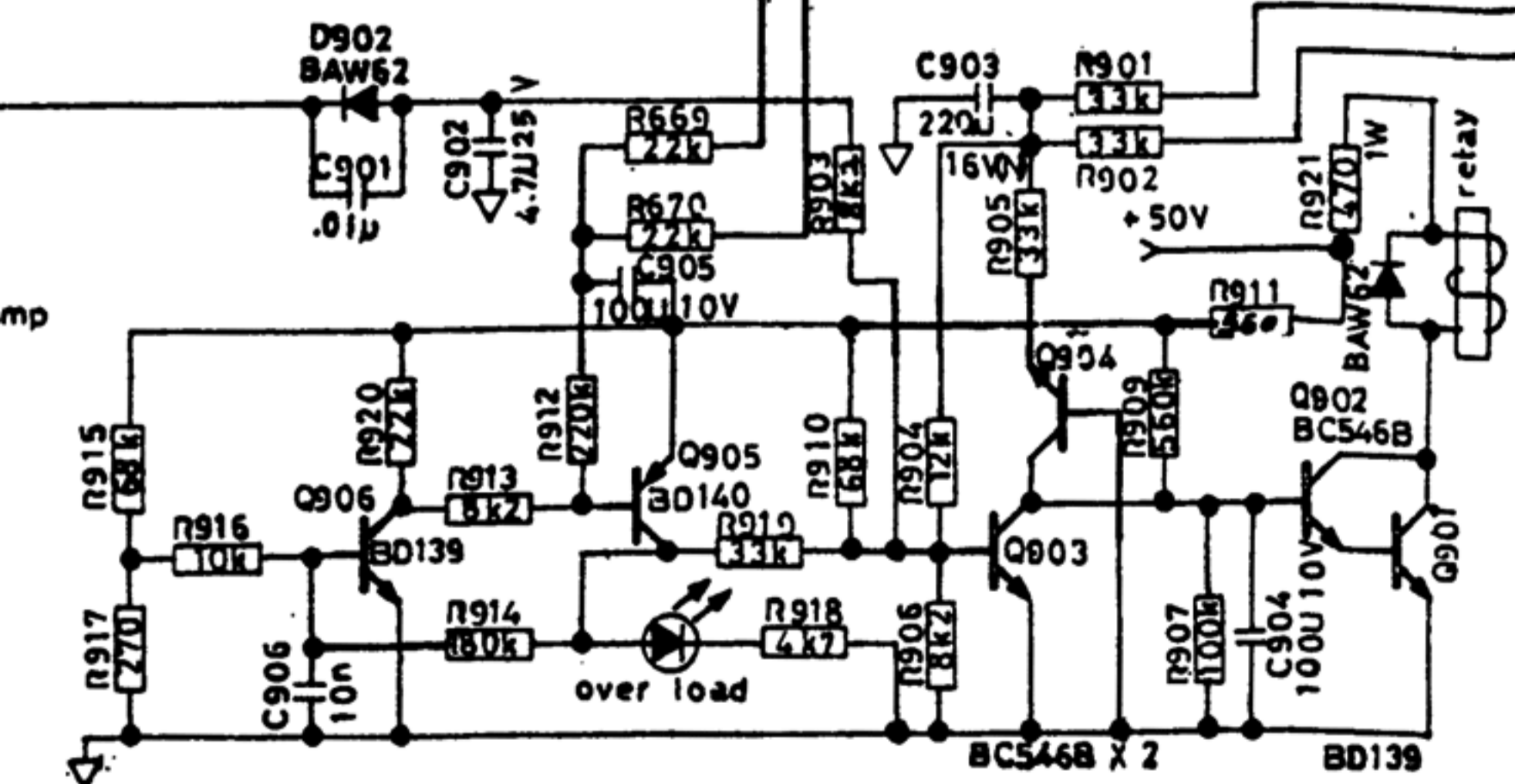
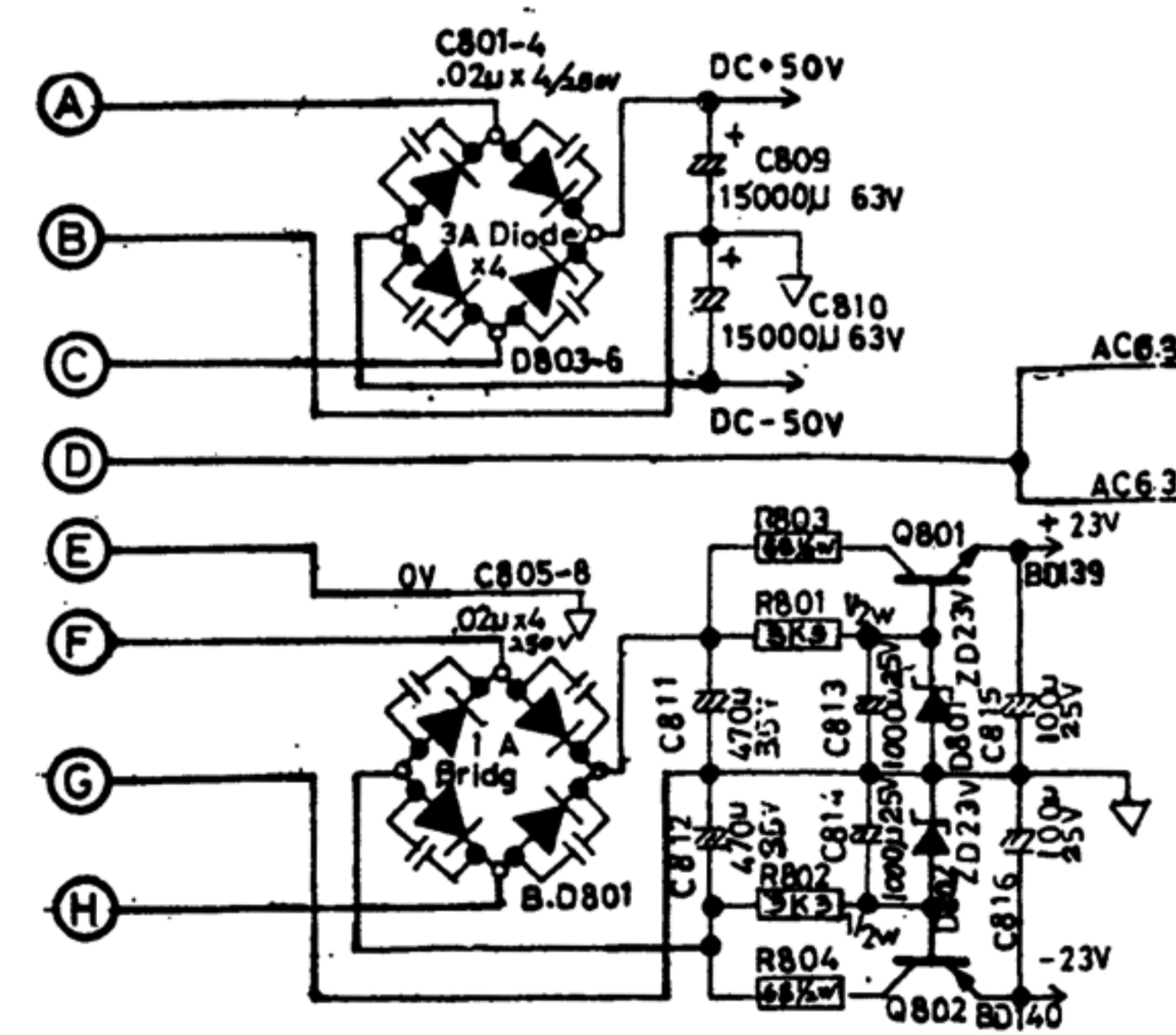

- A — ORANGE
- B — BLACK
- C — ORANGE
- D — BLUE
- E — BLUE
- F — RED
- G — GRAY
- H — RED
- I — BROWN
- J — WHITE
- K — YELLOW

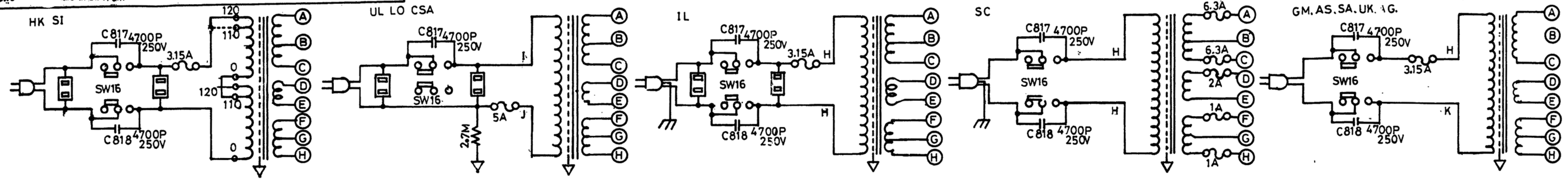

PARTS LIST

90-1048 MAIN SECTION				
ITEM	PARTS NO	DESCRIPTION	Q'TY	SYMBOL NO
1	16-½CP220J	CARBON RES. 22 OHM ½W ± 5%	6	R631, 632, 633, 634, 635, 636
2	16-½CP332J	CARBON RES. 3.3 OHM ½W ± 5%	2	R801, 802
3	16-½CP680J	CARBON RES. 68 OHM ½W ± 5%	2	R805, 806
4	16-¼CM101J	CARBON RES. 100 OHM ¼W ± 5%	2	R515, 516
5	16-¼CM102J	CARBON RES. 1K OHM ¼W ± 5%	12	R607, 608, 659, 660, 647, 648, 645, 646, 671, 672, 673, 674
6	16-¼CM103J	CARBON RES. 10K OHM ¼W ± 5%	5	R509, 510, 521, 522, 916
7	16-¼CM104J	CARBON RES. 100K OHM ¼W ± 5%	1	R907
8	16-¼CM123J	CARBON RES. 12K OHM ¼W ± 5%	1	R904
9	16-¼CM153J	CARBON RES. 15K OHM ¼W ± 5%	6	R539, 540, 655, 656, 657, 658
10	16-¼CM181J	CARBON RES. 180 OHM ¼W ± 5%	2	R513, 514
11	16-¼CM182J	CARBON RES. 1.8K OHM ¼W ± 5%	2	R604, 603
12	16-¼CM184J	CARBON RES. 180K OHM ¼W ± 5%	1	R914
13	16-¼CM221J	CARBON RES. 220 OHM ¼W ± 5%	4	R503, 504, 619, 620
14	16-¼CM222J	CARBON RES. 2.2K OHM ¼W ± 5%	4	R517, 518, 519, 520
15	16-¼CM223J	CARBON RES. 22K OHM ¼W ± 5%	5	R611, 612, 669, 670, 920
16	16-¼CM224J	CARBON RES. 220K OHM ¼W ± 5%	3	R601, 602, 912
17	16-¼CM271J	CARBON RES. 270 OHM ¼W ± 5%	1	R917
18	16-¼CM273J	CARBON RES. 27K OHM ¼W ± 5%	2	R609, 610
19	16-¼CM330J	CARBON RES. 33 OHM ¼W ± 5%	2	R629, 630
20	16-¼CM331J	CARBON RES. 330 OHM ¼W ± 5%	2	R621, 622
21	16-¼CM332J	CARBON RES. 3.3K OHM ¼W ± 5%	4	R505, 506, 617, 618
22	16-¼CM333J	CARBON RES. 33K OHM ¼W ± 5%	4	R901, 902, 905, 919
23	16-¼CM334J	CARBON RES. 330K OHM ¼W ± 5%	4	R501, 502, 527, 528
24	16-¼CM392J	CARBON RES. 3.9K OHM ¼W ± 5%	8	R507, 508, 523, 524, 525, 526, 531, 532
25	16-¼CM471J	CARBON RES. 470 OHM ¼W ± 5%	2	R511, 512
26	16-¼CM472J	CARBON RES. 4.7K OHM ¼W ± 5%	1	R918
27	16-¼CM561J	CARBON RES. 560 OHM ¼W ± 5%	1	R911
28	16-¼CM564J	CARBON RES. 560K OHM ¼W ± 5%	1	R909
29	16-¼CM682J	CARBON RES. 6.8K OHM ¼W ± 5%	2	R535, 536
30	16-¼CM683J	CARBON RES. 68K OHM ¼W ± 5%	2	R910, 915
31	16-¼CM821J	CARBON RES. 820 OHM ¼W ± 5%	2	R623, 624
32	16-¼CM822J	CARBON RES. 8.2K OHM ¼W ± 5%	5	R605, 606, 903, 913, 906
33	16-¼CN101J	CARBON RES. 100 OHM ¼W ± 5%	2	R613, 614
34	16-¼CN221J	CARBON RES. 220 OHM ¼W ± 5%	4	R529, 530, 619, 620
35	16-¼CN2R2J	CARBON RES. 2.2 OHM ¼W ± 5%	4	R665, 666, 667, 668
36	16-¼CN561J	CARBON RES. 560 OHM ¼W ± 5%	2	R615, 616
37	16-¼CN820J	CARBON RES. 82 OHM ¼W ± 5%	2	R533, 534
38	16-¼CU5R6J	CARBON RES. 5.6 OHM ¼W ± 5%	2	R651, 652
39	16-1003	RES. MPC 71 0.22 OHM 5W	8	R637, 638, 639, 640, 637A, 638A, 639A, 640A
40	16-1A102J	METAL OXIDE RES. 1K 1W ± 5%	2	R627, 628
41	16-1A152J	METAL OXIDE RES. 1.5K 1W ± 5%	2	R625, 626
42	16-1A222J	METAL OXIDE RES. 2.2K 1W ± 5%	4	R661, 662, 663, 664
43	16-1A471J	METAL OXIDE RES. 470 OHM 1W ± 5%	1	R921
44	16-2A100I	METAL OXIDE RES. 10 OHM 2W ± 5%	4	R641, 642, 643, 644
45	17-0.63E227Y	ELEC. CAPA. 220 μF 6.3V ± 50%	2	C505, 506
46	17-0.63E336Y	ELEC. CAPA. 33μF 6.3V ^{+50%} / _{-10%}	2	C629, 630
47	17-1.6E226Y	ELEC. CAPA. 22μF 16V ^{+50%} / _{-10%}	2	C604, 603
48	17-1.6S227Y	ELEC. CAPA. 220μF 16V ^{+50%} / _{-10%}	1	C903
49	17-1E106Y	ELEC. CAPA. 10μF 10V ^{+50%} / _{-10%}	2	C525, 526
50	17-1E107Y	ELEC. CAPA. 100μF 10V ^{+50%} / _{-10%}	2	C904, 905
51	17-1E226Y	ELEC. CAPA. 23μF 10V ^{+50%} / _{-10%}	2	C605, 606
52	17-2.5E106Y	ELEC. CAPA. 10μF 25V ^{+50%} / _{-10%}	4	C511, 512, 533, 534
53	17-2.5E107Y	ELEC. CAPA. 100μF 25V ^{+50%} / _{-10%}	2	C815, 816
54	17-2.5E108Y	ELEC. CAPA. 100μF 25V ^{+50%} / _{-10%}	2	C813, 814
55	17-2.5E475Y	ELEC. CAPA. 4.7μF 25V ^{+50%} / _{-10%}	1	C902

ITEM	PARTS NO	DESCRIPTION	Q'TY	SYMBOL NO
56	17-25D223K	CER. CAPA. 0.0022 μ F 250V \pm 10%	8	C801, 802, 803, 804, 805, 806, 807, 808
57	17-3.5E477Y	ELEC. CAPA. 470 μ F 35V + 50% - 10%	2	C811, 812
58	17-5D100D	CER. CAPA. 10PF \pm 0.5P 50V	2	C509, 510
59	17-5D101M	CER. CAPA. 100PF \pm 20% 50V	4	C609, 610, 627, 628
60	17-5D103M	CER. CAPA. 0.1 μ F \pm 20% 50V	6	C639, 640, 641, 642, 901, 906
61	17-5D104M	CER. CAPA. 0.1 μ F \pm 20% 50V	16	C607, 608, 631, 632, 633, 634, 635, 636, 637, 638, 617, 618, 623, 624, 623A, 624A
62	17-5D121M	CER. CAPA. 120P \pm 20% 50V	4	C619, 620, 645, 646
63	17-5D220M	CER. CAPA. 22P \pm 20% 50V	2	C611, 612
64	17-5D221M	CER. CAPA. 220P \pm 20% 50V	4	C503, 504, 531, 532
65	17-5D330M	CER. CAPA. 33P \pm 20% 50V	4	C527, 528, 529, 530
66	17-5D470M	CER. CAPA. 47P \pm 20% 50V	4	C507, 508, 615, 616
67	17-5D471M	CER. CAPA. 470P \pm 20% 50V	2	C601, 602
68	17-5D680M	CER. CAPA. 68P \pm 20% 50V	2	C643, 644
69	17-5D820M	CER. CAPA. 82P \pm 20% 50V	2	C613, 614
70	17-5E476Y	ELEC. CAPA. 47 μ F 50V + 50% - 10%	2	C625, 626
71	17-5F104J	MYLAR CAPA. 0.1 μ F 50V \pm 5%	8	C517, 518, 519, 520, 521, 522, 523, 524
72	17-5F 122J	MYLAR CAPA. 0.0012 μ F \pm 5%	4	C513, 514, 515, 516
73	17-5F224J	MYLAR CAPA 0.22 μ F 50V \pm 5%	2	C501, 502
74	19-1048	PCB FOR MAIN AMP. TONE. POWER SUPPLY	1	
75	29-1040	INDUCTOR 0.6x6 ϕ x15T	2	L601, 602
76	29-4057	BASS CONTROL 20KBx2	1	VR503A, VR503B.
77	29-4058	TREBLE CONTROL 50KBx2	1	VR501A, VR501B.
78	29-4060	BALANCE CONTROL 100KMN	1	VR505, 505A.
79	30-1011	ZENER DIODE 12V 0.5W	4	D611, 612, 613, 614.
80	30-1016	ZENER DIODE 23V 0.5W	2	D801, 802
81	30-1017-2	DIODE G3D 100V	4	D803, 804, 805, 806
82	30-1019	DIODE BAW62	24	D501, 502, 503, 504, 505, 506, 507, 508, 509, 510, 601, 602, 603, 604, 605, 606, 607, 608, 615, 616, 617, 618, 901, 902.
83	30-1040	BRIDGE DIODE W02	1	B.D801.
84	30-2082	TRANSISTOR BD140	2	Q802, 905.
85	30-2083	TRANSISTOR BD139	3	Q801, 901, 906.
86	30-2084-3	TRANSISTOR BC549C	4	Q503, 504, 505, 506.
87	30-2085-2	TRANSISTOR BC559B	4	Q501, 502, 507, 508
88	30-2086	TRANSISTOR 2SB536M	2	Q609, 610
89	30-2087	TRANSISTOR 2SD381M	4	Q605, 606, 607, 608
90	30-2090-2	TRANSISTOR BC546B	13	Q509, 510, 511, 612, 603, 604, 621, 622, 903, 904, 902, 625, 606.
91	30-2096	TRANSISTOR BC556A	4	Q601, 602, 623, 625.
92	30-3010	IC, CA3100	2	IC601, 602.
93	31-1020	LEVER SW. SLC-142	4	SW5a.b. SW7a.b SW6a.b. SW8a.b.c.d.
94	35-3002	RELAY SD-2059	1	
90-1074 PHONO PREAMP. SECTION				
95	16- $\frac{1}{4}$ CM102J	CARBON RES. 1K OHM $\frac{1}{4}$ W \pm 5%	2	R435, 436.
96	16- $\frac{1}{4}$ CM 124J	CARBON RES. 120K OHM $\frac{1}{4}$ W \pm 5%	2	R437, 438
97	15- $\frac{1}{4}$ CM.153J	CARBON RES. 15K OHM $\frac{1}{4}$ W \pm 5%	2	R419, 420.
98	16- $\frac{1}{4}$ CM 221J	CARBON RES. 220 OHM $\frac{1}{4}$ W \pm 5%	2	R411, 412.
99	16- $\frac{1}{4}$ CM 331J	CARBON RES. 330K OHM $\frac{1}{4}$ W \pm 5%	2	R401, 402.
100	16- $\frac{1}{4}$ CM 472J	CARBON RES. 4.7K OHM $\frac{1}{4}$ W \pm 5%	2	R425, 426
101	16- $\frac{1}{4}$ CM 562J	CARBON RES. 5.6K OHM $\frac{1}{4}$ W \pm 5%	2	R423, 424
102	16- $\frac{1}{4}$ CM 684J	CARBON RES. 680K OHM $\frac{1}{4}$ W \pm 5%	2	R411, 412
103	16- $\frac{1}{4}$ CN 151J	CARBON RES. 150 OHM $\frac{1}{4}$ W \pm 5%	2	R417, 418
104	16- $\frac{1}{4}$ CN 331J	CARBON RES. 330 OHM $\frac{1}{4}$ W \pm 5%	2	R415, 416
105	16- $\frac{1}{4}$ CN 680J	CARBON RES. 68 OHM $\frac{1}{4}$ W \pm 5%	4	R427, 428, 429, 430.
106	16- $\frac{1}{4}$ M 222J	METAL FILM RES. 2.2K OHM $\frac{1}{4}$ W \pm 5%	4	R406, 405, 407, 408.
107	16- $\frac{1}{4}$ M 272J	METAL FILM RES. 2.7K OHM $\frac{1}{4}$ W \pm 5%	2	R433, 434
108	16- $\frac{1}{4}$ M 333J	METAL FILM RES. 33K OHM $\frac{1}{4}$ W \pm 5%	2	R431, 432.
109	16- $\frac{1}{4}$ M 392J	METAL FILM RES. 3.9K OHM $\frac{1}{4}$ W \pm 5%	2	R409, 410.
110	16- $\frac{1}{4}$ M 560J	METAL FILM RES. 56 OHM $\frac{1}{4}$ W \pm 5%	2	R413, 414.
111	16- $\frac{1}{4}$ M 563J	METAL FILM RES. 56K OHM $\frac{1}{4}$ W \pm 5%	2	R403, 404.
112	17-0.63E 687Y	ELEC. CAPAC. 680 μ F 6.3V \pm 5%	2	C047, 408.
113	17-1E 106Y	ELEC. CAPA. 10 μ F 10V +50% -10%	2	C401, 402
114	17-2.5E 106Y	ELEC. CAPA. 10 μ F 25V +50% -10%	2	C417, 418
115	17-5D100D	CER. CAPA. 10PF \pm 0.5P 50V	2	C405, 406

ITEM	PARTS NO	DESCRIPTION	Q'TY	SYMBOL NO
116	17-5D 101M	CER. CAPA. 100PF $\pm 20\%$ 50V	2	C403,404
117	17-5D 104M	CER. CAPA. 0.1 μ F $\pm 20\%$ 50V	2	C423,424
118	17-5D 221M	CER. CAPA. 220PF $\pm 20\%$ 50V	2	C409,410
119	17-5D 473M	CER. CAPA. 0.047 μ F $\pm 20\%$ 50V	1	C425
120	17-5E 336Y	ELEC. CAPA. 33 μ F 50V $+50\%$ -10%	2	C415,416
121	17-5F 104J	MYLAR CAPA. 0.1 μ F 50V $\pm 5\%$	2	C411,412
122	17-5F 222J	MYLAR CAPA. 0.0022 μ F 50V $\pm 5\%$	2	C419,420
123	17-5F 273J	MYLAR CAPA. 0.027 μ F 50V $\pm 5\%$	2	C413,414
124	19-1074	PCB FOR EQ & FUNCTION	1	
125	30-1019	DIODE BAW62	8	D401,402,403,404, 405,406,407,408
126	30-2084-3	TRANSISTOR BC549C	2	Q403,404
127	30-2085-2	TRANSISTOR BC559B	4	Q401,402,405,406
128	30-2090-2	TRANSISTOR BC546B	2	Q409,410
129	30-2096	TRANSISTOR BC556A	4	Q407,408,411,412
130	31-1024-1	SELECTOR SW. SRZV044N	1	SW1a.b.c.d.
131	31-1043	SWITCH SRZ-V043N	1	SW4a.b.c.d.

90-1067 FILTER MIC SECTION

132	16-1/4CM 101J	CARBON RES. 100 OHM 1/4W $\pm 5\%$	1	R500
133	16-1/4CM 102J	CARBON RES. 1K OHM 1/4W $\pm 5\%$	5	R717,718,729,730,301
134	16-1/4CM 105J	CARBON RES. 1M OHM 1/4W $\pm 5\%$	2	R709,710.
135	16-1/4CM 121J	CARBON RES. 120 OHM 1/4W $\pm 5\%$	2	R725, 726
136	16-1/4CM 124J	CARBON RES. 120K OHM 1/4W $\pm 5\%$	7	R713,714,723,724,302,309,310
137	16-1/4CM 182J	CARBON RES. 1.8K OHM 1/4W $\pm 5\%$	1	R311.
138	16-1/4CM 222J	CARBON RES. 2.2K OHM 1/4W $\pm 5\%$	3	R701,702,308
139	16-1/4CM 272J	CARBON RES. 2.7K OHM 1/4W $\pm 5\%$	2	R721,722
140	16-1/4CM 274J	CARBON RES. 270K OHM 1/4W $\pm 5\%$	1	R304
141	16-1/4CM 332J	CARBON RES. 3.3K OHM 1/4W $\pm 5\%$	2	R547,548
142	16-1/4CM 333J	CARBON RES. 33K OHM 1/4W $\pm 5\%$	2	R703,704
143	16-1/4CM 392J	CARBON RES. 3.9K OHM 1/4W $\pm 5\%$	2	R719,720
144	16-1/4CM 393J	CARBON RES. 39K OHM 1/4W $\pm 5\%$	2	R711,712
145	16-1/4CM 471J	CARBON RES. 470 OHM 1/4W $\pm 5\%$	1	R303
146	16-1/4CM 473J	CARBON RES. 47K OHM 1/4W $\pm 5\%$	3	R312,313,314
147	16-1/4CM 474J	CARBON RES. 470K OHM 1/4W $\pm 5\%$	2	R715,716
148	16-1/4CM 562J	CARBON RES. 5.6K OHM 1/4W $\pm 5\%$	4	R705,706,707,707
149	16-1/4CM 822J	CARBON RES. 8.2K OHM 1/4W $\pm 5\%$	3	R727,728,305
150	16-PCN391J	CARBON RES. 390 OHM 1/4W $\pm 5\%$	1	R307
151	16-1/4CN 471J	CARBON RES. 470 OHM 1/4W $\pm 5\%$	1	R303
152	16-1/4CU 153J	CARBON RES. 15K OHM 1/4W $\pm 5\%$	2	R553,554
153	17-0.63E 107Y	ELEC. CAPA. 100 μ F 6.3V $+50\%$ -10%	1	C304
154	17-1E 106Y	ELEC. CAPA. 10 μ F 10V $+50\%$ -10%	1	C301
155	17-2.5E 106Y	ELEC. CAPA. 10 μ F 25V $+50\%$ -10%	4	C713,714,305,308
156	17-2.5E 475Y	ELEC. CAPA. 4.7 μ F 25V $+50\%$ -10%	2	C709,710
157	17-2.5E 476Y	ELEC. CAPA. 47 μ F 25V $+50\%$ -10%	1	C307
158	17-5D 104M	CER. CAPA. 0.1 μ F 50V $\pm 20\%$	2	C715,716
159	17-5D 220M	CER. CAPA. 22PF 50V $\pm 20\%$	2	C711,712
160	17-5D 391M	CER. CAPA. 390PF 50V $\pm 20\%$	2	C535,536
161	17-5D 470M	CER. CAPA. 47PF 50V $\pm 20\%$	2	C303,306
162	17-5D 561M	CER. CAPA. 560PF 50V $\pm 20\%$	1	C302
163	17-5F 124J	MYLAR CAPA. 0.12 μ F 50V $\pm 5\%$	4	C705,706,707,708
164	17-5F 222J	MYLAR CAPA. 0.0022 μ F 50V $\pm 5\%$	2	C703,704
165	17-5F 224J	MYLAR CAPA. 0.22 μ F 50V $\pm 5\%$	2	C537,538
166	17-5F 562J	MYLAR CAPA. 0.0056 μ F 50V $\pm 5\%$	2	C701,702
167	19-1067	PCB FOR FILTER & MIC & VOLUME CONTROL	1	
168	29-4020-1	VOLUME CONTROL VMBE-VER22-5KB	1	VR301
169	29-4047	VOLUME CONTROL 50KBx2 41 CLICK	1	VR507,507A
170	30-2084-3	TRANSISTOR BC549C	2	Q301,302
171	30-2090-2	TRANSISTOR BC546B	2	Q701,702
172	30-2096	TRANSISTOR BC556A	2	Q703,704
173	31-1040	PUSH SW. 5KEY 2V	1	SW10a.b. SW11, SW12a.b. SW13a.b. SW14a.b.

90-1069 METER DRIVER SECTION

174	16-1/4CM 103J	CARBON RES. 10K OHM 1/4W $\pm 5\%$	2	R203,204
175	16-1/4CM 104J	CARBON RES. 100K OHM 1/4W $\pm 5\%$	2	R207,208
176	16-1/4CM 224J	CARBON RES. 220K OHM 1/4W $\pm 5\%$	2	R209, 210
177	16-1/4CM 392J	CARBON RES. 3.9K OHM 1/4W $\pm 5\%$	2	R201,202
178	16-1/4CM 681J	CARBON RES. 680 OHM 1/4W $\pm 5\%$	2	R213,214
179	16-1/4CM 821J	CARBON RES. 820 OHM 1/4W $\pm 5\%$	2	R205,206
180	16-1/4CN 221J	CARBON RES. 220 OHM 1/4W $\pm 5\%$	2	R211,212

ITEM	PARTS NO	DESCRIPTION	Q'TY	SYMBOL NO
181	17-0.63E 226Y	ELEC. CAPA. 23 μ F 6.3V +50% -10%	2	C203,204
182	17-1E 106Y	ELEC. CAPA. 10 μ F 10V +50% -10%	2	C201,202
183	19-1069	PCB FOY METER AMP	1	
184	29-4022	SEMIFIXED RES. 5K	2	VR201,202.
185	30-1019	DIODE BAW62	2	D203,204
186	30-2090-2	TRANSISTOR BC546B	2	Q201,202
Others				
187	16- $\frac{1}{4}$ CM 102J	CARBON RES. 1K OHM $\frac{1}{4}$ W \pm 5%	4	R523,524,525,526
188	16- $\frac{1}{4}$ CM 104J	CARBON RES. 100K OHM $\frac{1}{4}$ W \pm 5%	2	R549,550
189	16- $\frac{1}{4}$ CM 394J	CARBON RES. 390K OHM $\frac{1}{4}$ W \pm 5%	2	R551,552
190	16-1003	RES. MPC71 0.22 OHM 5W \pm 5%	8	R675,676,677,678,679,680, 681,682
191	16-10B 5ROJ	CEMENT RES. 5 OHM 10W \pm 5%	1	R676
192	16-2A471J	METAL OXIDE RES. 470 OHM 2W \pm 5%	2	R683,684
193	17-6.3P159Y	ELEC. CAPA. 15000 μ F/63V +50% -10%	2	C809,810
194	19-1047	PCB FOR TAPE	1	
195	19-1055	PCB FOR TRANSISTOR	4	
202	19-1076	PCB FOR TAPE MONITOR	1	
196	30-1037	RED LED 3 ϕ	1	
197	30-2083	TRANSISTOR BD139	2	Q619,620
198	30-2088	TRANSISTOR 2SD287BR	4	Q611,612,613,614
199	30-2109	TRANSISTOR 2SB539BR	4	Q615,616,617,618
	31-1002	SWITCH 6P	1	
200	31-1021	SPEAKER ROTARY SW. (SRY-2044)	1	SW15A-D
203	31-1025T	PUSH SW. 2KEY 2U	1	SW2a.b. SW3a.b.
201	35-1014	POWER METER	2	
204	12-2006	AC OUTLET	2	FOR IL,UL,SI,UK,SA,CSA
205	16- $\frac{1}{2}$ CP275K	CARBON FILM 2.7M OHM $\frac{1}{4}$ W \pm 10%	1	FOR UL, CSA
206	17-2001	CER. CAPA. ECK-DHS472MD	2	FOR: EC,SC,IL,SI,HK,AG,SA.
207	17-2003	CER CAPA. ECK-DEL472EZ	2	FOR: UL,CSA.
208	17-2004	CER. CAPA ECK-DGS472MD4	2	FOR: UK,AS
209	29-2017A	POWER TRANSOFRMER	1	FOR: SI, HK, SA
210	29-2017A-1	POWER TRANSFORMER 117V	1	FOR: UL
211	29-2017A-2	POWER TRANSFORMER-240V	1	FOR: UK,AS.
212	29-2017A-3	POWER TRANSFORMER 220V	1	FOR: EC,SC,IL,AG
213	29-2017A-4	POWER TRANSFORMER120V	1	FOR: CSA
214	31-1072A	POWER SW.	1	FOR: UL,CSA
215	31-1073A	POWER SW.	1	FOR: EC,SC,IL,UK,AS,SI,HK, AG,SA
216	32-11001SS	FUSE 1A SEMCO	4	FOR: SC
217	32-12001SS	FUSE 2A SEMCO	2	FOR: SC
218	32-13151SS	FUSE 3.15A SEMCO	2	FOR: EC,IL,UK,AS,AG,SA
219	32-13001UT	FUSE 3A UL	2	FOR: SI,HK.
220	32-15001UT	FUSE 5A UL	2	FOR: UL,CSA
221	32-16301SS	FUSE 6.3A SEMCO	4	FOR: SC
222	32-2001	FUSE HOLDER S-N 1301	1	FOR UL,SI,HK.
223	32-2003	FUSE HOLDER S-N 2250	1	FOR: IL, SA.
224	32-2005	FUSE HOLDER	1	FOR: CSA.